

Operation Manual

RYOUSEI Dust collector

Thank you for purchasing the RYOUSEI Dust Collector at this time.

In order to use our machine correctly, ensure to read this manual. It will certainly help you to solve problems, if you encounter problems or questions while you use it.

Check the serial number of manufacturing nameplate on the product and the serial number printed on the guarantee card. Because the serial number of the product is important for quality control.

In this manual, the safety instructions are divided to “Warning” and “Caution.”

Warning If you mishandle the product, that may cause a serious injury or death as a result.

Caution If you mishandle the product, that may cause a minor or moderate injury or a material damage as a result.

Before Use

- (1) Check item
On receiving the machine, check the following points.
- Check the manufacturing nameplate (type, output, voltage, frequency).
 - Check whether there is the damage by the accident in transportation. If you find something wrong, check the type of machine and the serial number. And then contact us.

- (2) Transfer and installation
- Warning**
- Transfer and install the machine by someone who has expert knowledge. When you transfer and install the machine, take care not to drop or overturn it. Because that may cause an injury. In the machine installed the lifting bolts, use the lifting bolts when you transfer and install the machine.
- Caution**
- Ensure to place the machine on a flat place. If it is necessary, do the work of foundation. Because that may cause falling of the machine.
 - In the case of a wooden frame package, pay attention to the nail in unpacking. Because that may cause an injury.
 - Keep the warning label sticker visible at all times, and don't peel it off or conceal it by an obstruction.

- (3) Place of use
- Warning**
- In place of the flammability or explosive atmosphere, do not use the machine in a normal model. Because that may cause an injury or a fire. If you use the machine at the place of Article 280 to 282 indicated in Occupational Health and Safety Regulation, use explosion-proof model is suitable for such a place.
- Caution**
- Except for the model of outdoor, do not use the machine outdoors. Because that may cause a short circuit.
 - In modification of our product, we do not have guarantee of the product.

- (4) Instructions in connecting the power supply
- Warning**
- Connect wiring of the machine by someone who has the expert knowledge. Because that may cause an electric shock, injury or a fire. In connecting the power supply, refer to the wiring diagram.
 - To prevent an electric shock accident from a short circuit, connect the main body to the earth (a ground resistance of 100Ω or less). The Ground wire is green. (Articles 18 to 28 indicated in Electric Equipment and Technology Standards).
- Caution**
- Connect the cable and wire according to the Electric Equipment and Technology Standards and the electric power company's instructions. If the wiring distance is long, the voltage drop occurs. So, select the electrical capacity so that the voltage drop is less than or equal to 2%.
 - All of our products (except for the product is especially designed) have an overload protection device, but we recommend that you install a circuit breaker to prevent from a fire or an electric shock.
 - Use the machine by the specified voltage, frequency on the manufacturing nameplate. Use the breaker of the required power supply's capacity (about three times of the capacity marked on the manufacturing nameplate).

- (5) Check direction of motor rotation
- After connecting power supply, check direction of motor rotation by running the fan. Open the inspection door or remove the top plate in some model. And check it to the direction of the arrow by your eyes.
- Warning**
- Check direction of motor rotation by your eyes. Do not touch the motor by your fingers or tool. Because that may cause an injury.
- Caution**
- In the case of a reverse rotation, connect wiring again in exchanging the red and black wires. Even if the motor can run in the reverse direction, the machine does not work well. Also that may cause the motor overloaded or burn out.

Instructions for use

- (1) Power supply
- Make sure that the power supply cable or the power supply plug is securely connected before use. If you do not connect wiring properly, that may cause the motor burn out. Also, single-phase operation may cause the motor burn out.
- Warning**
- Do not bend the power supply cable or pinch it. Because that may cause an electric shock. Also, the cable or code dissolves by the gasoline or oil. Take care for dealing with them.
 - When you use the machine, do not run it with opening the control panel or terminal box door. Because that cause an electric shock.
 - In the case of a power outage, stop working the machine or turn off primary power supply. Because the machine may automatically start running by a recovery from the power outage.

- (2) Operation
- Warning**
- Regardless of whether the machine is working, prevent from putting a burning substance or an equivalent into the suction port. Because that may cause a fire. During operation, do not touch the machine carelessly by your hands or something with opening the inspection door. Because that may cause an injury.
 - If you use the machine in an inflammable, an explosive powder or gas and install the machine in a hazardous atmosphere, please use the machine that has an explosion-proof structure with criteria required electrical and structural.
- Except for the machine is especially designed, our machine is for dry dust only. Do not suck oil or wet dust.
 - When you suck a large amount of particulate powder such as cement, lime, chemical, or toner, exhaust the dust to the outside through the filter. So, use the machine installed the HEPA filter in the clean room, such as a hospital or a chemical company, etc.
 - Sometimes, you cannot use the machine any more. Because the model is not suitable for your dust. (For example, if you set it up the other place or change the dust suction.)

- (3) Dust disposal
- Dispose the dust as soon as possible. If you keep the dust in the dust bucket (hopper) for a long time, that may cause clogging of the filter or a fire.
 - After working the mechanism of removing the dust, take out the dust in the dust bucket each time. In removing the dust bucket, check to stop the machine completely.
 - After pulling down the bucket handle and cheking the dust bucket is down, you take away the dust bucket. In somemodels, move the bucket handle to the right.
 - When you open and close the outlet port of the machine installed the hopper, do it little by little not to scatter the dust.

- (4) Mechanism of removing the dust
- RV, RSV, RC, RSC, and RF Series
- When you use the dust collector for a long time, the machine does not work well for the dust on the filters. In this case, stop running the machine once and remove the dust from the filter by working the mechanism of removing the dust.
 - In the machine installed the manual shaking mechanism, shake the shaking handle several times to take the dust away from the filter.
 - In the machine installed the electric power shaking mechanism, you can remove the dust automatically. (When you stop the fan, you can work the shaking motor 60 seconds later consquently.) In depending on the type or the amount of the dust, the time is shaking is usually 60 seconds. You can change the waiting time of shaking and running time of shaking. Turn the volume knob in the programmable controller in the control panel.
- VR1 : Waiting time of shaking 60 ~ 310 seconds (60 seconds at factory)
VR2 : Running time of shaking 0 ~ 250 seconds(60 seconds at factory)
- If you want the machine to start and stop frequently, the running time of shaking is long consquently. So, the lifetime of the filter may be short. In this case, adjust the shaking time and tortal running time of shaking is less than or equal to 5 five minutes per day.
- RSP Series
- In the machine installed the pulse jet cleaning mechanism, you can remove the dust automatically. (When you start running the fan, the machine works the pulse jet cleaning mechanism automatically at setting your interval.) In using the machine, connect your compressor (0.4~0.5 MPa) to the air receiving port (air filter) on the side of the main body.
 - At the factory, interval of operating the solenoid valves is 60 seconds during running the fan. Also, after you stop running the fan, the solenoid valves work at interval of 5 seconds in 60 seconds. You can change interval of the operating and running time after the fan stops. Turn the volume knob in the programmable controller in the control panel.

Maintenance and Inspection in using for a long time

- (1) Maintenance
- Caution**
- Before starting maintenance, repairing, or disassembling, turn off the main power supply or primary power supply to avoid an electric shock, injury, or a fire.

- ※Caution of maintenance
- In maintenance, ensure enough safety acordding to the safety's standard of your company and Occupational Health and Safety Regulation.
 - In maintenance, put on working clothes and wear protective equipment (dustproof mask, safety glasses or etc).
 - If you are dealing with flammable materials, be strictly prohibited fire.
 - If you do not run the machine in maintenance, turn off the primary power supply and indicate the running prohibition.

- ※Maintenance item
- Before running the machine
- Inspect the appearance to check if there is any harmful deformation or damage on the function.
 - Ensure that the maintenance door is closed and the dust bucket is definitely set up the right position.
 - Ensure that the dust in the dust bucket (hopper) is disposal.
- During operation
- Check no air leaks from the packing of the maintenance door or dust bucket.
 - Make sure that the indicator lights turn on in the control panel.
 - The motor has the ball bearings. Also, the bearings of the machine have worn or damage by the dust leaked through the filter. So, check the noise from the motor.
 - Open all the inlet port of the pipes or ducts and check an electric current by the ammeter. If the current value is much lower than the rated value, the filter may be clogging.

- In inspecting regularly or disassembling
- Check the filter after opening maintenance door. If the filter is clogging heavily, wash or clean it. If you find something wrong, replace it with a new one.
 - Inspect the packing of maintenance door and the dust bucket. If you find the unacceptable deformation or deterioration, replace it with a new one.
- Other parts
- Check the hood, hose, and pipe is correctly installed and there is no deformation or damage. In running the fan, check no air leaks from the connection. In addition, if you find the dust inside, clean it.
 - Inspect the control panel. If you find the dust inside, that may cause a leak current to the ground or a short circuit. So, clean it regularly.
 - Inspect the filter's case. If you find a lot of dust, the filter may be installed incorrectly, torn off, or broken.

- (2) Replacement of the filter
- In using the machine for a long time, the filter will be clogging, worn or broken. So, wash the filter or replace it with a new one every year. If you wash the filter, check it carefully to find damage of the filter.
 - Sometimes, the machine does not work well by working the mechanism of removing the dust. In such a case, remove the filter from the main body and clean it by an electric cleaner or wash it by water (if you use a commercial cleaner in washing, you can clean the filter more effectively). In additon, please install the filter after the filter is completely dry.
 - Sometimes, you cannot wash the filter by the filter's type. In such a case, contact us.

- Cautions**
- Before inspecting or replacing the filter, turn off the primary power supply and ensure the machine stops working completely.
 - When you install or remove the filter, be careful not to cut your fingers by the mounting plate. So, when you install or remove the filters, we recommend putting on the protective gloves.
 - If the filter is incompletely installed, the dust may be discharged from the outlet port. So, install the filter correctly.

○RV, RSV, RC, RSC, and RF Series

- Remove the port rubber of the filter with giving the force to the port rubber of the filter.
- Remove the lock rubber in the filter hanger tip. If you use RF series, remove the split pin and flat washer.
- Remove the filter from the filter hanger.
- Remove all of the filter in the same way. In installing the filters, follow the procedure in reverse. At this time, do not install the filter with being twisted. Also, install the port rubber to the mounting plate collectly.

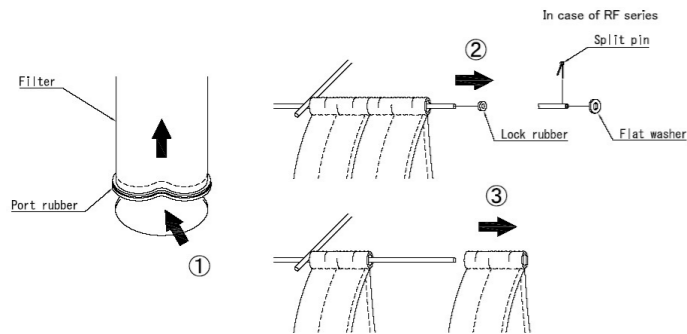

○RSP Series

In this series, we have noted with A and B to the holder and the mounting position. In replacing a filter, ensure to match the symbol with each other.

- Loosen and remove the eye nut retaining the holder of A.
- Slightly pull out the holder of A.
- Remove the filters in order.
- Remove the holder of A from the rail. Remove the filters from the holder of B in the same way. In installing the filters, at first, install the holder of B and the filters in reverse order. At next, install the holder of A and the filters in reverse order. Also, check the filter not to be broken.

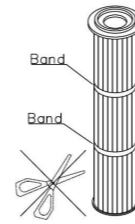

After installing the filters, touch the filters to check there are no loose. If the packing at the top of the filter is deforming, exchange with a new one. Also, do not cut the filter's band in using your machine.

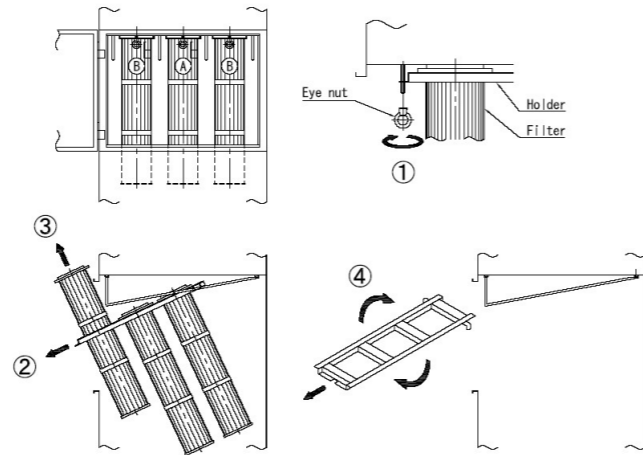

○RC-560 Series

- Remove the fixing nuts of the maintenance door to open the maintenance door.
- Loosen the butterfly screws at the bottom of the filter. (2pieces)
- Pull out the filter.

○RSM Series

- Remove the catch-clip to open the maintenance door.
- Remove the hose band of one-touch, remove the dust-collecting bag.
- Open the fastener of the dust-collecting bag and dispose of the dust. In addition, it is useful to carry the dust-collecting bag by using the handle.

○RSV-211B Type(RV-05B Type)

- Remove the catch-clip to open the maintenance door.
- Pull out the dust bucket.
- Loosen the butterfly screw at the bottom of the filter. (2pieces)
- Pull out the filter.

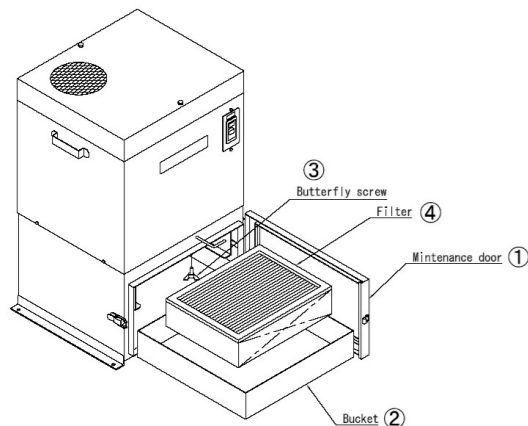

○RSP-520 Series

- Loosen the fastener bolts (4pieces) at the top in the filter case.
- Frame that holds the filter is coming down.
- Pull out the filters.
- In installing the filter, follow the procedure in reverse. Check that the packing at the top of the filter is in close contact with the top part in the filter case.

After installing the filters, touch the filters to check there are no loose. If the packing at the top of the filter is deforming, exchange with a new one. Also, do not cut the filter's band in using your machine.

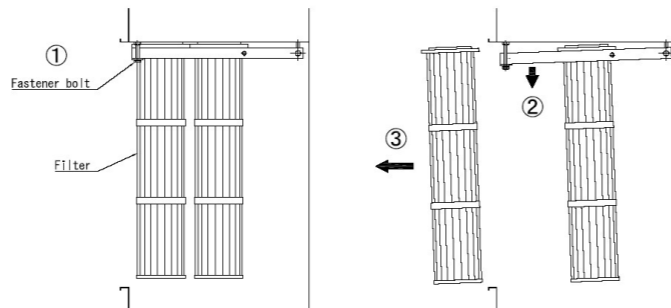
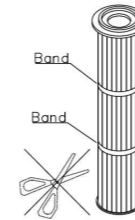

○HEPA filter

In the machine installed the HEPA filter, the dust passing through the primary filter will be collected by the HEPA filter. Also, the HEPA filter cannot be reused, replace it with a new one in a certain period of time (the final pressure loss of 0.5 kPa or more in reading the differential pressure).

(3) Replacing the motor

The fan's motor has the ball bearings. So, if you use the machine for a long time, the ball bearings will have been worn or damaged by contaminating the dust or depending on the condition of use. In such a case, the noise in or vibration from the motor is something wrong. So, pay attention to the running noise in operation. If the noise and vibration from the motor is something wrong, repair or replace the motor.

- Loosen the lifting bolts (2 or 4 pieces) and remove the lifting bolts and the top plate.
- In the machine installed the HEPA filters, the HEPA filters and the HEPA case, remove them.
- Remove the wiring is connected to open the terminal box of the motor.
- Loosen the bolts of the motor's mounting plate (3 or 4 pieces) by the lifting bolt of the motor and remove them and motor's mounting plate.
- Lift up the motor's mounting plate using hanging bolt of the motor or the part of fixing the motor and remove the motor and fan with the motor's mounting plate. In lifting down the motor's mounting plate on the floor, ensure that the fan is upward.
- Loosen the bolt in the center of the motor's shaft and remove it and pull out the fan by your hands. If you may pull out the fan forcibly, the shaft of the motor and fan will be damaged.
- Remove the motor from the motor's mounting plate by removing the fixing bolts and nuts.

■ If you find something wrong, please check your machine at first

Condition	Possible cause	Countermeasure
Do not run even if you turn on the switch	Power supply does not turn on	Turn on power supply
	Overload protection device works	After checking, start again
	Overload relay of magnetic switch works	After checking, reset it
	Switch is something wrong	Repair or replacement
	Motor is something wrong	Repair or replacement
Motor stops in operation	Reverse operation	Check direction of motor rotation.
	Protection device works to start and stop frequently	Wait for minutes and then restart running.
	Motor is something wrong	Repair or replacement
Vibration or noise is bigger	Motor bearing has damage	Repair or replacement
	Part of mounting motor are loosen	Tighten bolt
Dust leaking from exhaust port	Filter has damage	Replacement
	Setting up filter is not good	Check and set up again
Reduce the power of suction or do not vacuum	Clogging of filter	Wash or replacement
	Dust bucket is full of dust	Dispose dust
	Setting up dust bucket is not good	Check and set up again
	Clogging in duct or hose	Clean the inside
	Deformation or damage of duct or hose	Replacement
	The connection of duct or hose is not good	Check and connect again

■ After-Sales Service

- Guarantee period
The guarantee period is one year from the day purchasing our machine.
- When you repair the machine during the guarantee period
Inspect your machine according to the list "If you find something wrong, please check your machine at first." If you can not solve the problem, contact us.
- When you repair the machine after the guarantee period
Contact us. If we judge the machine keeps the performance by repairing, we will repair the machine with fee.
- Minimum holding period for maintenance or repair parts.
We keep the maintenance or repair parts of our machine at least six years after discontinued production.
- If you have any question about after-sales service, such as repairing in the guarantee period, contact us.
- This guarantee and service are valid only in Japan.

RYOUSEI Co., Ltd.

2-6-8 Obata Minami, Moriyama-ku, Nagoya 463-0048, Japan

Nagoya Head Office Phone (052) 794-3211

Tokyo Sales Office Phone (03) 3835-4451

Osaka Sales Office Phone (06) 6302-8055

Fukuoka Sales Office Phone (092) 947-2821